

LW-800 series

MARCH, 1958

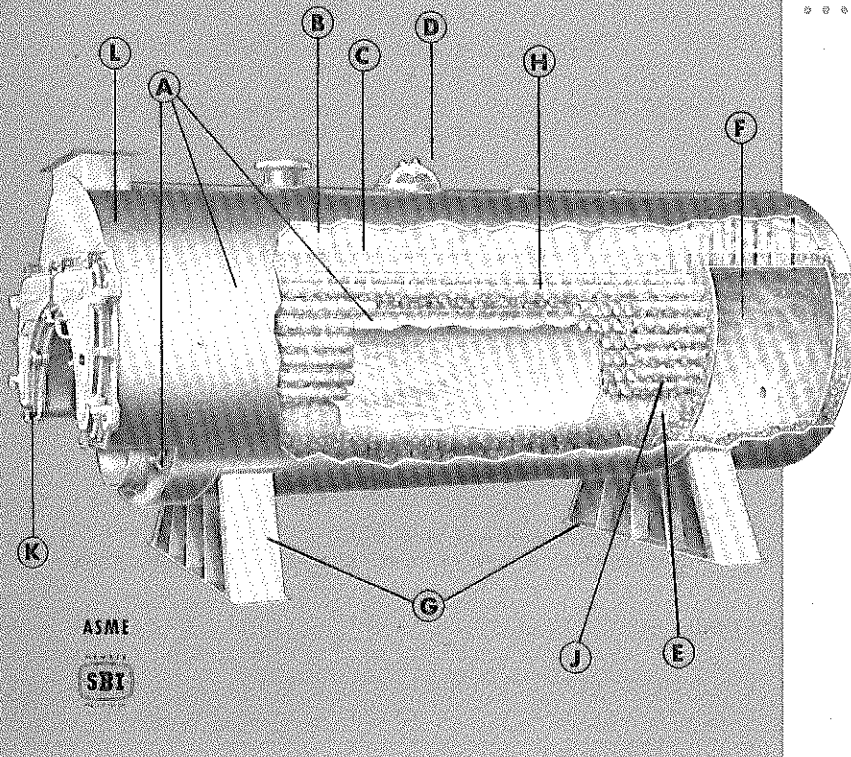

ASME
SBI

1,313,000 to 21,855,000 Btuh for low pressure steam or hot water heating 250° max.

The low pressure wet-back scotch type Kewanee LW-800 is designed, built and rated with 8.2 sq ft of heating surface per boiler horsepower when sized on SBI rating. Certified ratings are based on 5.5 sq ft of heating surface. This ample amount of heating surface safely provides sufficient steam in reserve . . . lower fuel and maintenance costs, longer, more dependable boiler life. It will generate steam with efficiency throughout its entire firing range, and can be fired far above its rated nominal capacity without interrupting its usual economical operation.

low pressure oil or gas

- A Shell, heads and furnace** are shaped from heavy flange steel. All welds in accordance with ASME Code.
- B Ample steam space** insures dry steam. Water content is sufficient to hold water line steady.
- C Unbroken steam disengaging area** permits steam to rise without undue turbulence.
- D 11 x 15 in. manhole** and adequate washout openings give access to waterside.
- E Flanged openings** in tube sheets for attaching plain circular furnace provide for greater flexibility.
- F Wet-back design** offers additional primary heating surface entirely surrounded by water for more complete heat transfer. An access opening provides entrance through rear of boiler into the furnace and rear combustion chamber.
- G Sturdy steel saddle supports** simplify handling and installation. No special base is required.
- H Long gas travel**, through the lengthy combustion chamber, then back through the full length of heavy gage 3" tubes, assures maximum transfer of heat to boiler water.
- J Rapid circulation** through the unobstructed waterways speedily sweeps the steam bubbles up without commotion . . . an important factor in making LW-800 a fast steamer.
- K Insulated cast iron flue doors**, gasketed for permanent gas-tight fit, provide easy access to fire tubes for cleaning and inspection. (Steel doors on LW-891, 892 and 893.)
- L Gas-tight smokebox** of heavy gage steel . . . welded in one piece to boiler shell. Rectangular smoke outlet located at top.

ratings • mechanically fired—oil or gas

boiler number	LW-878	LW-879	LW-880	LW-881	LW-882	LW-883	LW-884	LW-885	LW-886	LW-887	LW-888	LW-889	LW-890	LW-891	LW-892	LW-893
SBI rating — steam sq ft	5470	6080	7290	8500	10330	12150	15180	18220	21250	24290	30360	36430	42500	48570	54640	60710
— water sq ft	8750	9720	11660	13600	16520	19440	24280	29150	34000	38860	48570	58280	68000	77710	87420	97140
— MBtuh	1313	1459	1750	2040	2479	2916	3643	4373	5100	5830	7286	8743	10200	11657	13114	14570
— steam per hour — 212° F. lb	1350	1520	1790	2100	2550	3000	3760	4490	5240	6000	7490	9000	10490	11970	13460	14970
SBI net rating — steam sq ft	4500	5000	6000	7000	8500	10000	12500	15000	17500	20000	25000	30000	35000	40000	45000	50000
— water sq ft	7200	8000	9600	11200	13600	16000	20000	24000	28000	32000	40000	48000	56000	64000	72000	80000
— MBtuh	1080	1200	1440	1680	2040	2400	3000	3600	4200	4800	6000	7200	8400	9600	10800	12000
certified output — MBtuh	1969	2188	2625	3060	3718	4374	5464	6559	7650	8745	10929	13114	15300	17485	19671	21855
*firing rate — oil** gph	16	18	22	26	31	37	46	54	64	73	91	110	127	146	164	182
— gas MBtuh	2460	2740	3280	3830	4650	5460	6840	8200	9560	10920	13670	16400	19120	21900	24600	27300
heating surface (SBI min) sq ft	322	358	429	500	608	715	893	1072	1250	1429	1786	2143	2500	2857	3214	3571
furnace volume (SBI min) cu ft	39.1	43.5	52.1	60.8	73.8	86.8	108.5	130.2	151.8	173.5	216.9	260.3	303.6	346.9	390.3	433.6
net furnace volume cu ft	49.2	52.7	61.7	68.1	83.4	92.0	111.3	137.0	152.3	179.0	221.0	266.8	336.8	355.6	396.7	435.7
safety valve capacity lb steam per hr	1969	2188	2625	3060	3718	4374	5464	6559	7650	8745	10929	13114	15300	17485	19671	21855

*Firing rates calculated to develop boiler output of 150% of SBI rating.
**Based on 150,000 Btu oil.

Standard equipment — Gas-tight front steel smokebox; rear end access panel with refractory lining and pyrex observation port. Steel saddle supports. Flue cleaner and handle. Washout plug wrench and extra set of gaskets.
Additional equipment, trim, furnace extensions, insulating jackets and skirts furnished at extra cost.

Standard steam trimmings — Safety valve(s) as required by ASME Code, steam gage with siphon and cock, water column with water gage and try cocks assembly. Chain operated water column trimmings on LW-888 and larger.

Standard water trimmings — Relief valves, or relief and safety valves as required by ASME Code for low pressure boilers.

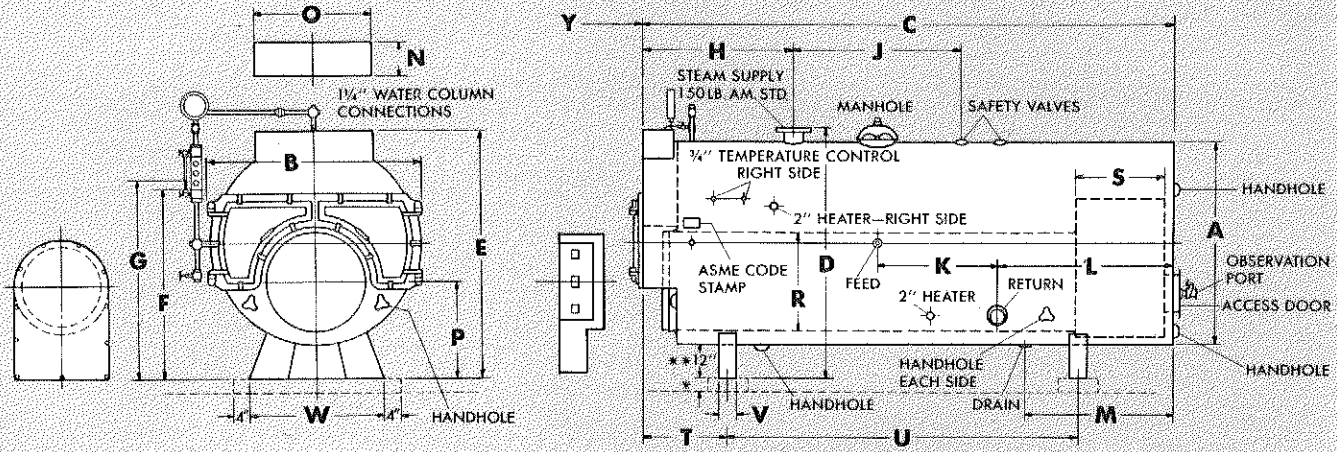

*Additional height not by Kewanee Boiler Division.
 **Supports attached permanently to boiler when insulating jacket or piping is furnished.



LW-800 series low pressure • oil or gas

dimensions and data (feet—inches)

boiler number	LW-878	LW-879	LW-880	LW-881	LW-882	LW-883	LW-884	LW-885	LW-886	LW-887	LW-888	LW-889	LW-890	LW-891	LW-892	LW-893
A — boiler inside diameter	4-6	4-6	5-0	5-0	5-6	5-6	6-0	6-6	6-6	7-0	7-6	8-0	8-6	8-10	9-2	9-6
B — boiler width	4-9	4-9	5-4	5-4	5-9	5-9	6-3	6-9	6-9	7-3	7-9	8-3	8-9	9-1	9-5	9-9
C — boiler length	10-8	11-7	10-10	12-2½	12-4	14-0½	15-1½	15-1½	17-1½	17-2	18-4½	19-4½	19-8	20-4	20-10½	21-7
D — steam supply height	6-0	6-0	6-6	6-6	7-0½	7-0½	7-6½	8-0½	8-0½	8-6½	9-1½	9-7½	10-1½	10-5	10-9	11-1
E — smoke outlet height	5-11	5-11	6-5	6-5	6-11	6-11	7-5	7-11	7-11	8-5	8-11½	9-5½	9-11½	10-3	10-7	10-11
F — water column height	4-6	4-6	4-10½	4-10½	5-2½	5-2½	5-6	5-10	5-10	6-3	6-8½	7-1	7-6½	7-10	8-1	8-4
G — water line height	4-8	4-8	5-0½	5-0½	5-4½	5-4½	5-8	6-0	6-0	6-5	6-10½	7-3	7-8½	8-0	8-3	8-6
H — steam supply	3-0	3-6	3-1	3-7	3-8	4-2	4-9	4-10	5-4	5-5	5-5	5-6	5-7	5-8	6-0	6-0
J — safety valve*	5-4	5-9	5-2	5-10	5-9	7-0	7-0	7-0	8-0	7-0	8-2	9-0	9-0	9-0	9-0	9-0
K — feed water, each side	2-4	2-9	2-2	2-9½	2-7	3-5	3-7	3-7	4-1	3-7	4-1	4-5	4-5	4-2	3-10½	4-1
L — return, each side	3-4	3-4	3-7	3-9	3-11	3-11½	4-3½	4-2½	4-8½	5-8	5-10½	5-11½	6-2	7-0	7-6	8-0
M — drain	3-0	3-0	3-3	3-5	3-5	3-5½	3-5½	3-10½	3-10½	4-11	4-11½	4-10½	5-1	5-6	6-0	6-0
N — smoke outlet — outside width	0-11⅜	0-11⅜	1-0⅜	1-0⅜	1-1⅜	1-1⅜	1-2⅜	1-3⅜	1-3⅜	1-4⅜	1-4⅜	1-5⅜	1-6⅜	1-7⅜	1-8⅜	1-9⅜
O — — outside length	2-5⅞	2-5⅞	3-0⅞	3-0⅞	3-4⅞	3-4⅞	3-6⅞	3-11⅞	3-11⅞	4-7⅞	5-4⅞	5-7⅞	6-1⅞	6-5⅞	6-9⅞	7-1⅞
P — furnace — height	2-6	2-6	2-7½	2-7½	2-9	2-9	2-10½	3-0½	3-0½	3-2	3-3½	3-5½	3-7½	3-8½	3-10	3-10
R — — inside diameter	2-2¾	2-2¾	2-5¾	2-5¾	2-8½	2-8½	2-10¾	3-1¾	3-1¾	3-5	3-7½	3-10¾	4-4¾	4-4¾	4-6¾	4-6¾
S — — rear chamber	2-0	2-0	2-0	2-0	2-0	2-0	2-0	2-4	2-4	2-6	2-8	2-10	2-10	2-10	3-0	3-6
T — support — location	2-3	2-3	2-4	2-4	2-5	2-8	2-9	2-10	3-4	3-5	3-5	3-6	3-7	3-8	4-2	4-2
U — — center to center	6-11	7-10	6-9	7-11	8-1	9-6	10-6	10-6	12-0	11-0	12-0	13-0	13-0	13-6	13-6	13-6
V — — width	0-9	0-9	0-9	0-9	0-10	0-10	0-10	0-11	0-11	1-0	1-1	1-2	1-3	1-4	1-4	1-4
W — — length	4-0	4-0	4-5	4-5	4-10	4-10	5-3	5-6	6-1	6-1	6-6	7-0	7-6	7-10	8-2	8-6
Y — tube replacement space	6-6	7-5	6-6	7-10	7-10	9-6	10-4½	9-11	11-10½	11-7	12-7½	13-3	13-5	13-11	14-1	14-1½
breaching diameter — one boiler	1-9	1-10	1-11	2-0	2-2	2-4	2-6	2-7	2-9	2-11	3-3	3-5	3-7	3-10	4-0	4-2
stack — diameter	1-7	1-8	1-9	1-10	2-0	2-2	2-4	2-5	2-7	2-9	3-0	3-2	3-4	3-6	3-8	3-10
— height	35-0	40-0	35-0	40-0	40-0	45-0	50-0	50-0	55-0	50-0	55-0	55-0	55-0	60-0	60-0	60-0
breaching diameter — two boilers	2-3	2-4	2-6	2-7	2-10	3-0	3-4	3-5	3-8	3-11	4-2	4-6	4-8	5-0	5-3	5-6
stack — diameter	2-1	2-2	2-4	2-5	2-8	2-10	3-1	3-2	3-5	3-8	3-11	4-2	4-4	4-8	4-11	5-2
— height	40-0	45-0	40-0	45-0	45-0	50-0	55-0	55-0	60-0	60-0	60-0	60-0	60-0	65-0	65-0	65-0
steam supply size	6	6	8	8	8	8	8	8	8	8	10	10	10	12	12	12
return size (two)	4	4	4	4	4	4	4	4	4	4	6†	6†	6†	6†	6†	6†
drain size	1½	1½	2	2	2	2	2	2	2	2½	2½	2½	2½	2½	2½	2½
feed water size	1¼	1¼	1¼	1¼	1½	1½	1½	1½	1½	1½	1½	2	2	2½	2½	2½
outside surface to cover	163	177	186	208	233	263	308	337	378	410	470	529	572	610	650	696
approximate weight	6000	6400	7000	7900	10000	11200	13200	15200	16900	20300	24100	28000	32000	35000	38100	41300

*One or more valves furnished depending on required capacity.
 †150 lb American Standard Flange.

Equipment shown subject to change without notice.